



PROTEUS

Infinite possibilities

TSIM948xD 2/4 Channel Threat Simulator

The TSIM9482/4 is a compact bench threat simulator capable of generating coherent radio frequency (RF) signals up to 18GHz to emulate enemy radar, missile guidance systems, and electronic warfare (EW) threats. This tool is ideal for test and evaluation early in the development cycle, to validate modules/units such as Radar Warning Receivers - RWR) in a controlled lab environment, ensuring it can detect, identify, and counter sophisticated threats.



Built on Tabor Software Defined Radio Technology

Software-defined radio (SDR) is a radio system that uses software to process signals instead of hardware. SDRs are used in many fields, including mobile communications, military projects, and research and development. The Tabor Arbitrary Waveform Transceiver is a type of software define radio that is based on the concept of a system in a module. The core elements of the module are RF Digital to Analog and Analog to Digital Converters, user programable FPGA, large memory, and high speed data bus technology.

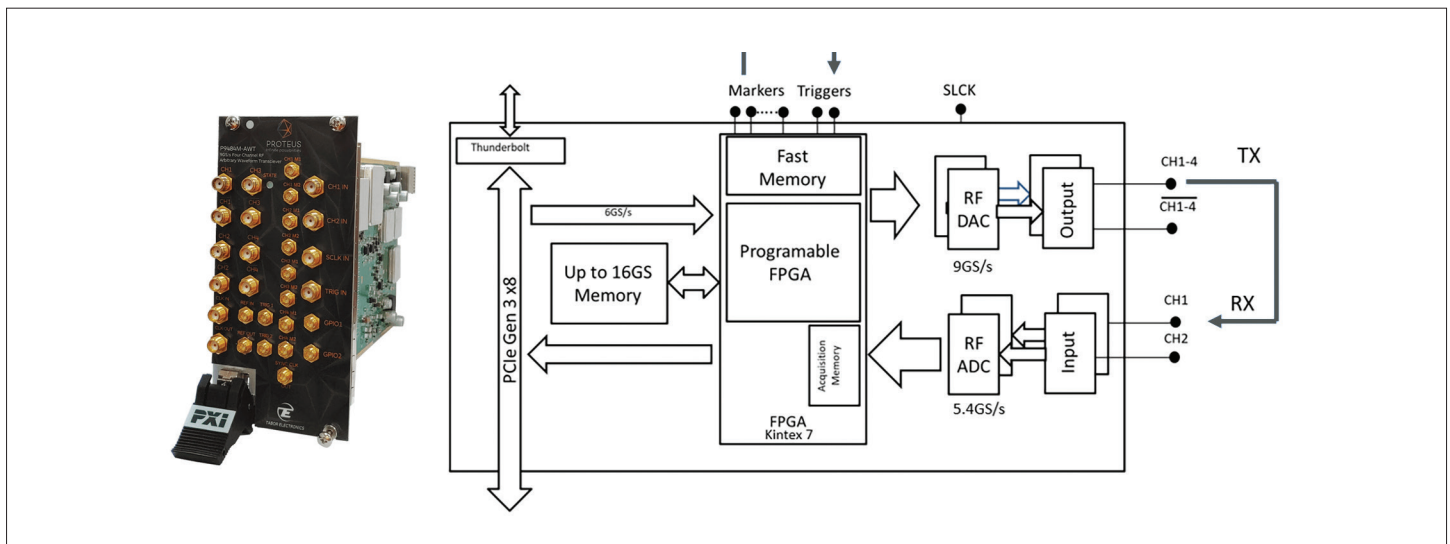

RF Tranceiver System in a Module





PROTEUS

Infinite possibilities

TSIM948xD - 2/4 Channel Threat Simulator

OUTPUTS	
TX CHANNELS	x = 2 or 4
MAX FREQUENCY RANGE	18GHz
FREQ ACCURACY	50ppb
FREQUENCY SWITCHING SPEED	<20us
TIME AND PHASE	Adjustable between channels
OSCILLATOR TYPE	Coherent (Return to previous frequency, with reproducible phase)
FREQ HOPPING WHILE MAINTAIN PHASE	At least three frequencies

MODULATION TYPES	
IQ	
IBW PER CHANNEL (IQ BW)	1GHz
IQ TYPES:	Internal , File, Stream
MAX MEMORY	8GS
PULSE	
WIDTH	50 ns to 5 μs
PRI	50kHz
CONTROL	Internal / Trig

CONTROL	
INTERFACE	LAN
SCENARIO PLAYBACK	Pulse Descriptor Words (PDW)
CONTROL MODES	Stream or Table
CONTROL FORMATS	ASCI (CSV), or BIN
CONTROL TYPE	Deterministic

REFERENCE	
FREQUENCY	10MHz/100MHz
SOURCE	Internal, External (Input and Output)

MECHANICAL	
DIMENSIONS	19in, 5u
ENVIRONMENT	Laboratory



All rights reserved to Tabor Electronics Ltd. Tabor makes no representations nor warranties with respect to the accuracy or completeness of the contents and reserves the right to make changes at any time without notice. Ver.1, revised March 6, 2026.