

Requirement

Testing new WiGig devices can be a challenging task, it requires testing tri-band devices which should support signals with 2.4GHz, 5GHz & 60GHz Carriers. Modulation Bandwidths are starting from a few MHz and up to 2GHz. The 802.11ad PHY supports four main signaling implementations:

- Control – Low throughput used for sending control channel messages.
- **Single Carrier (SC)** – Uses single carrier modulation schemes.
- **Low Power Single Carrier (LPSC)** – Uses single carrier in order to minimize the power consumption (for small handheld devices)
- **Orthogonal Frequency Division Multiplex (OFDM)** – Uses multicarrier modulation schemes to provide higher data throughput than single carrier methods.

Several digital modulation schemes are being used allowing a wide range of data rates:

Table 1: modulation schemes and different PHY's used in WiGig devices

Control PHY	
Modulation	Bit Rate
$\frac{\pi}{2}$ -DBPSK	27.5 Mbps
Single Carrier PHY	
Modulation	Bit Rate
$\frac{\pi}{2}$ -B/QPSK, $\frac{\pi}{2}$ -16QAM	385 Mbps-4.62 Gbps
OFDM PHY	
Modulation	Bit Rate
OFDM-SQ/QPSK, OFDM-16/64QAM	693 Mbps-6.75 Gbps
Low Power Single Carrier PHY	
Modulation	Bit Rate
$\frac{\pi}{2}$ -B/QPSK	626 Mbps-2.5 Gbps

One key element of the WiGig test setup is an Arbitrary Waveform Generator. An AWG is required for the creation of complex modulated wideband signals. Such AWG should be able to generate test signals at baseband, intermediate frequency (IF) & radio frequency (RF), with modulation bandwidths of more than 2GHz and advanced sequence abilities.

Measurements

- **Error Vector Magnitude (EVM)** – This measurement shows the error vector (difference) between an ideal constellation point and the transmitted/received point on the IQ plane:

$$EVM(\%) = \sqrt{\frac{P_{error}}{P_{ref}}}, EVM(dB) = 10\log_{10}\left(\frac{P_{error}}{P_{ref}}\right)$$

The impairments that may affect the EVM:

- Phase/Frequency Accuracy
 - Quadrature Error/Quadrature Imbalance
 - DC/Carrier Feedthrough
 - Jitter & noise
- **Signal to Noise Ratio (SNR)** – This measurement is the ratio between the required signal and the background noise (unwanted signal):

$$SNR(dB) = 10\log_{10}\left(\frac{P_{signal}}{P_{noise}}\right)$$

- Receiver minimum sensitivity – Minimum input signal required to produce a specified SNR at the output port of the receiver.
- Spectral Mask – The signal's spectral mask should comply with the following graph:

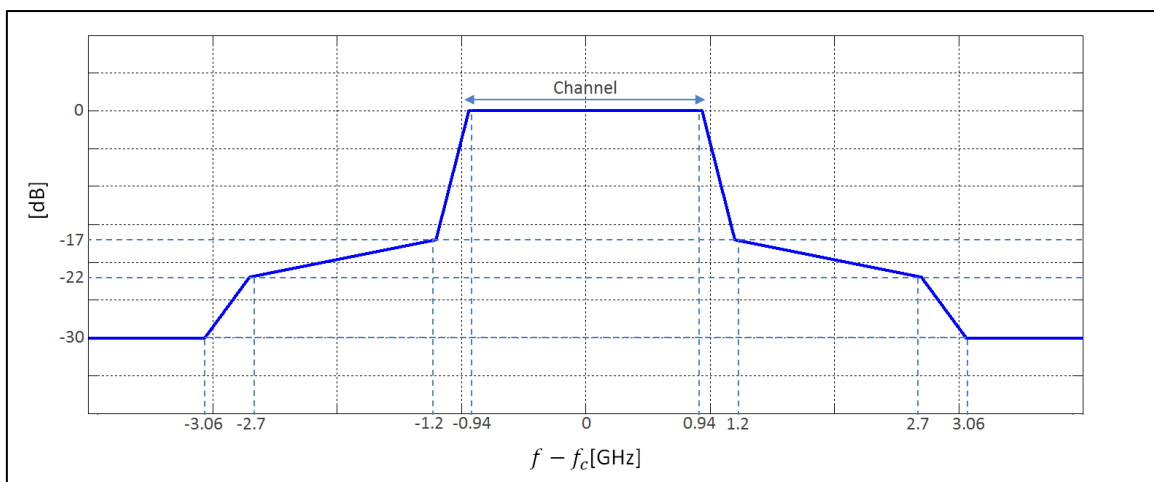

Figure 2: Spectral Mask of 802.11ad packet with RBW of 1MHz.

- P1dB point – Is a non-linearity test to determine the input signal power that will cause a decrease of 1dB from the expected linear gain plot:

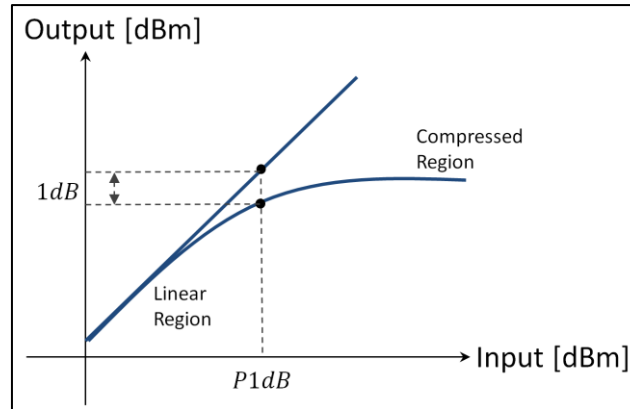

Figure 3: 1dB compression point

Simulations

Low frequency signals – for backwards compatibility of WiGig devices, there is a need to create test signals at relative low frequencies. Such baseband signals can be created using waveform creation software (such as MATLAB) and an AWG.

IF & RF Signals – For testing at 60GHz, a **Vector Signal Generator (VSG)** is being used to create an IF tone. Converting it to the required RF frequency is done using an Up-Converter and a microwave analog signal generator. An AWG will feed differential IQ signals into the IQ inputs of the VSG's internal modulator. As the modulated data will occupy a bandwidth that will reach up to 2GHz, an AWG with adequate IQ modulation bandwidth is required to produce such signals. IQ impairments, noise or other distortions should be added in order to simulate real world scenarios.

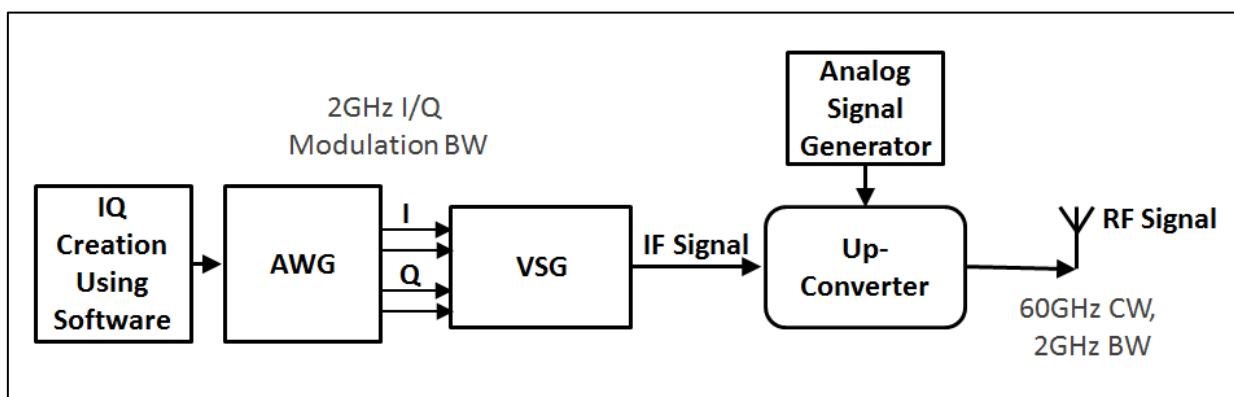

Figure 4: Typical WiGig receivers test setup using an AWG

Solution

Tabor Electronics SE5082 AWG

The SE5082 - Tabor Electronics High-speed AWG with its 5GS/s sample clock rate and 12-bit vertical resolution, up to 64Mpts of memory per channel, differential/single ended (optional) outputs and advance sequence abilities enables the user to generate I and Q components and even allows direct creation of multiple IF modulated carriers of any modulation scheme. The SE5082 has excellent accuracy and SFDR performance allowing high dynamic range. It comes with one or two independent/synchronized channels with adjustable skew (10ps resolution). Each of the AWG outputs with up to 2.5GHz of bandwidth and up to 5GHz of IQ modulation bandwidth.

- Tabor Electronics High speed AWGs specifically designed for IQ baseband signal generation, such as the SE5082, combined with an VSG (or other high-quality external modulator), allows for the generation of accurate modulated signals with up to 5 GHz of IQ modulation bandwidth.

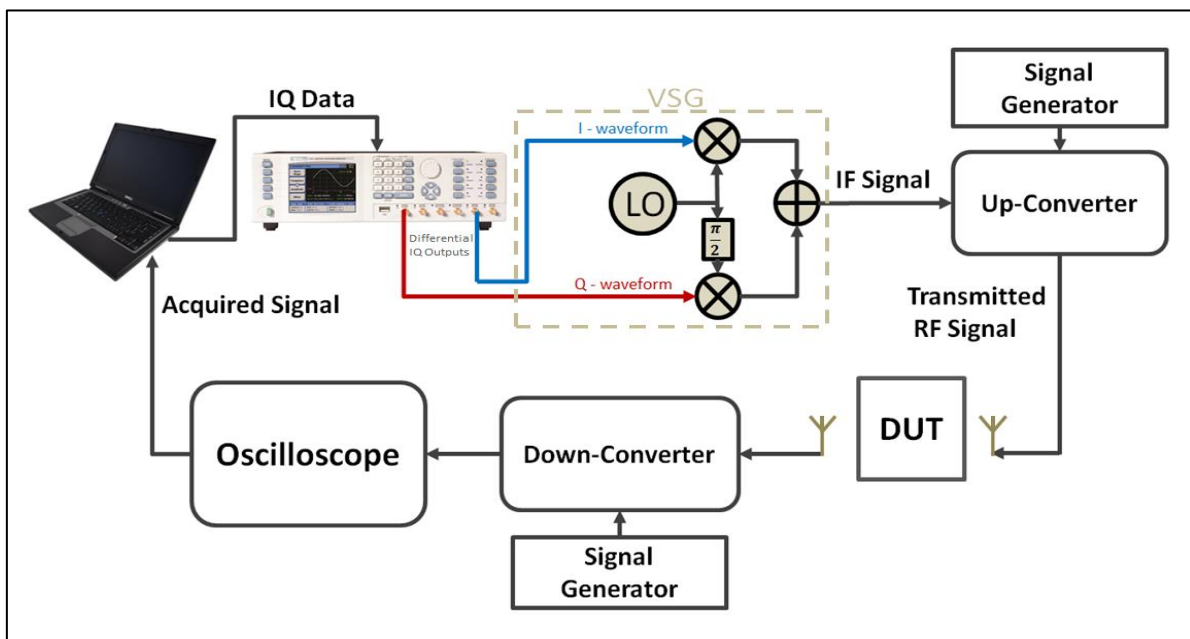

Figure 5: Creation of I/Q signals for a VSG using Tabor SE5082 AWG

- Tabor Electronics SE5082 AWG with its high sampling rate and excellent SFDR performance can directly generate multiple modulated IF/RF carriers. Two SE5082 units can be synchronized, allowing 4 synchronized channels with up to 2.5GHz of analog bandwidth.

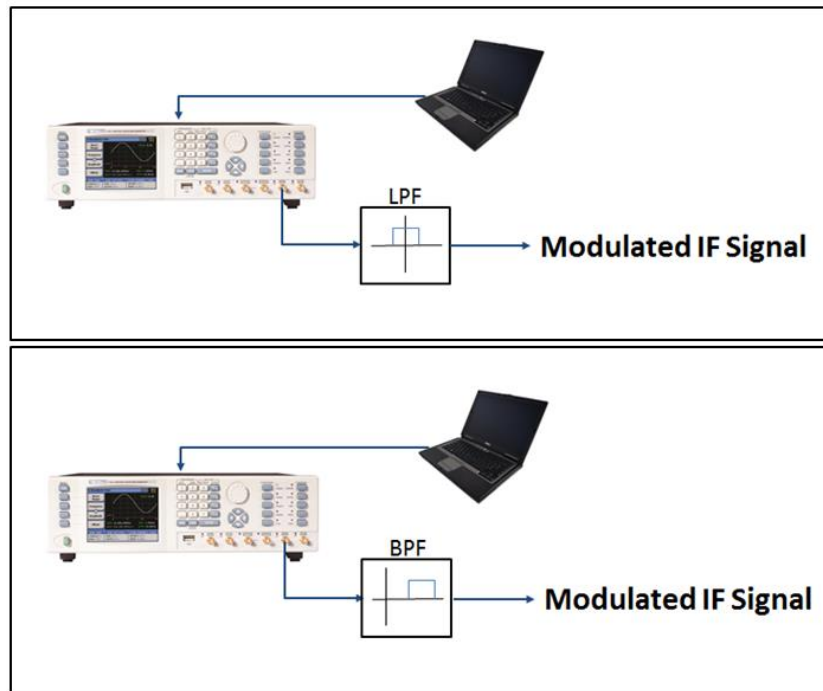

Figure 6: (a) Direct RF/IF generation using LPF for first Nyquist band. (b) Direct RF/IF generation using BPF for a higher Nyquist band

The new **Tabor Electronics Signal-Expert series of Arbitrary Waveform Generators** offers the best performance than any other unit on the market in its price range, featuring:

- 5Gs/s, 12 bit dual channel waveform generators
- Extra wide analog bandwidth of more than 7GHz
- Extremely fast rise and fall time of under 150ps
- Multi-Nyquist zone operation capability, up to the 4th Nyquist zone
- Selectable sampling modes for optimizing performance depending on the required Nyquist zone
- Independent or synchronized channels with 10ps inter channel skew resolution
- Up to 64M of waveform memory
- Various output amplifier modules utilized to solve numerous applications in different domains
- Smart trigger enables trigger hold-off, detect, wait, abort and restart
- Advanced sequencer for step, loop, nest and jumps scenarios
- Built-in fast dynamic segments and sequences hop control
- Two programmable markers (positions, width and levels) per channel
- Multi instrument synchronization

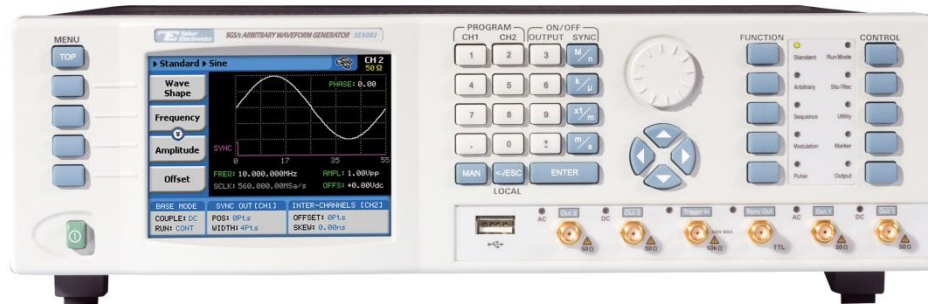

Figure 9: The Tabor SE5082 AWG

The **Signal Expert** series of **AWGs** enables the generation of extremely long scenarios. With a waveform memory of up to 64Mb per channel, with sequence and advance sequence modes, users can define the order and duration of each segment with nesting and looping of stored waveforms. Users can also define when to jump to the following segment with conditional jumping on events.

The Tabor SE5082 is appealing to WiGig developers due to its flexibility, excellent low noise performance, controllable channel delay, the ability to control & fine tune the amplitude of each outputted channel and finally the sequencing capabilities that allows individual sequence table per channel.

Pulse sequencing on the Tabor SE5082 can be created using MATLAB, Python, C++, and LABVIEW or by simply using the ArbConnection, which is a custom made remote control software, provided free of charge by Tabor Electronics.

Applications

Companies world-wide have already announced WiGig products and more and more companies are starting development of new devices based on the 802.11ad standard.

Gaming/Entertainment



Wireless Docking



Small Office



Hot - spots



For More Information

To learn more about Tabor's solutions or to schedule a demo, please contact your local Tabor representative or email your request to info@tabor.co.il. More information can be found at our website at www.taborelec.com

© Proprietary of Tabor Electronics Ltd.